

PARTS LIST

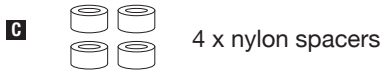
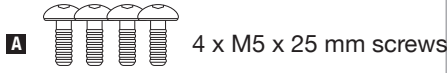

TOOLS REQUIRED

- hand drill
- 5.5 mm drill bit (7/32")
- 3 mm (7/16") allen wrench
- punch
- ruler
- paper template (pg. 2)
- masking tape

INSTALLATION: Remove the headlight mask and headlight **fig 1** (per manufacturer's instructions). Cut out paper template on pg. 2. Use a ruler to center template over the middle of the headlight mask **fig 2**.

Ensure position will not interfere with underside light or supports. Use masking tape to secure paper template in place. Mark hole centers with a punch. Use a 5.5 mm drill bit (7/32"), drill hole locations. **Use CAUTION when drilling to not damage the mask.**

Align windshield hole locations to the newly drilled holes in the headlight mask. Attach windshield **E** to the mask by inserting screw **A**, washer **B** and spacer **C** through the holes **fig 3**. Secure the windshield with washer **B** and nut **D** on the backside of the mask **fig 4a and fig 4b**. Tighten with an allen wrench. **DO NOT OVER-TIGHTEN.** Reconnect headlight and re-install headlight mask on motorcycle.

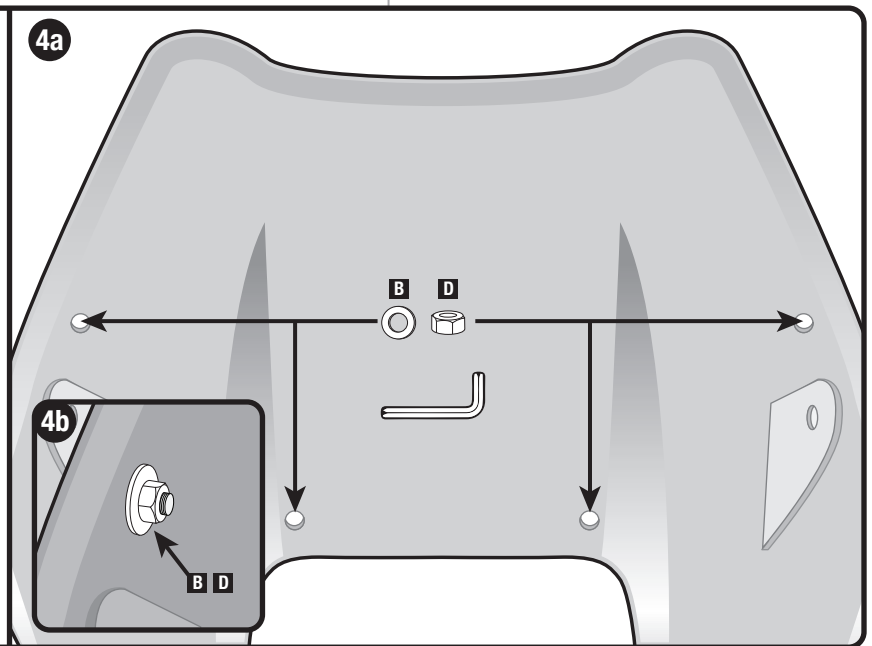
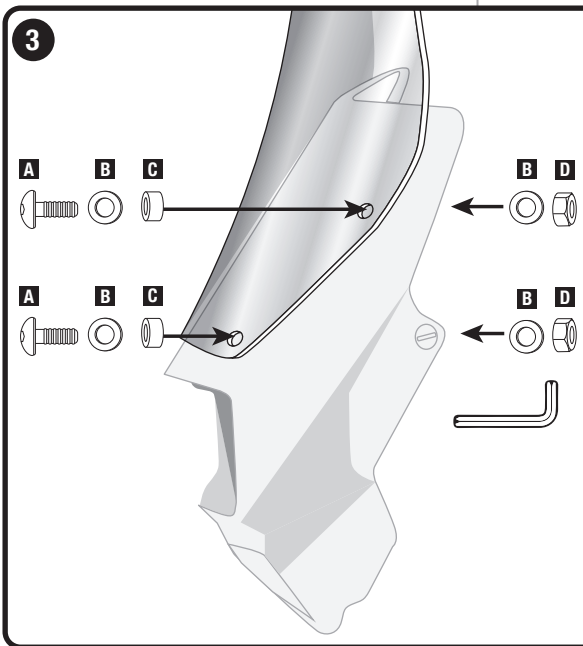
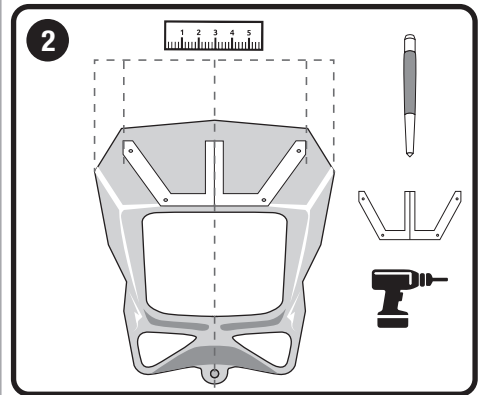
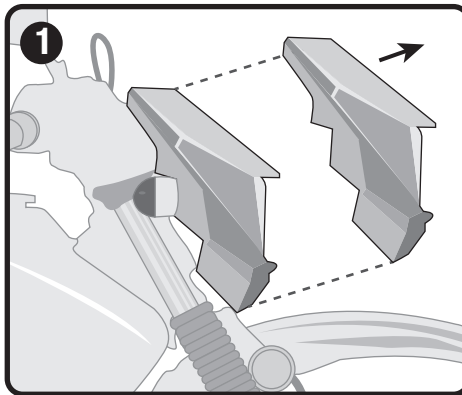

CLEANING INSTRUCTIONS



WARNING: Improper cleaning of your windshield will cause damage and void warranty.

Periodic cleaning of your polycarbonate windshield using correct procedures with compatible household cleaners is recommended to prolong the service life of your material. Your polycarbonate windshield is a hard coated, abrasion/mar resistant material that offers a high degree of scratch resistance and surface hardness.

General Cleaning: Thoroughly pre-rinse with warm water to loosen and wash away surface material, grit and grime. Use a soft microfiber cloth or moist non-abrasive sponge, gently wash with a mild diluted soap or detergent. Rinse thoroughly with lukewarm clean water. To prevent water spots thoroughly dry the glazing with a dry soft cloth.

Removing Heavy Oils & Tars

Thoroughly pre-rinse with warm water to loosen and wash away surface material, grit and grime. With 50/50 isopropyl alcohol-water mixture, gently rub the area with a soft non-abrasive cloth. Immediately rinse thoroughly with lukewarm clean water. To prevent water spots thoroughly dry with a soft cloth.

DO NOT use abrasive cleaners or high alkaline cleaners (high PH or ammonia). **DO NOT** leave cleaners sitting on polycarbonate for periods of time, wash off immediately. **DO NOT** apply cleaners under direct sunlight or at elevated temperatures. **DO NOT** use unapproved cleaners. Using scrapers, squeegees, razors or other sharp instruments may permanently scratch your polycarbonate. Always avoid dry rubbing/cleaning your polycarbonate as sand and dust particles cling to the exterior and may scratch the surface. An anti-static canned air ionizer can reduce electrostatic charge buildup on polycarbonate, consequently reducing dirt and dust buildup that would hinder cleaning.

RALLY MASK HOLE TEMPLATE INSTRUCTIONS

1. Cut out the template following the dotted contour.
2. Mark the center of the mask using a ruler.
3. Place the template on the mask ensuring the centerlines are aligned.
4. Secure with tape.
5. Mark and drill holes using 5.5 mm drill bit (7/32").
Follow detailed instructions on pg. 1.

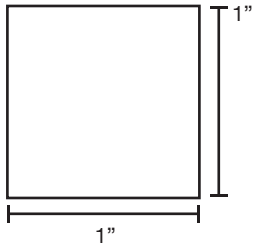

Due to printer scaling variations, verify this box measures 1" x 1" to ensure correct hole placement. Template can be downloaded at: www.bajaworx.com

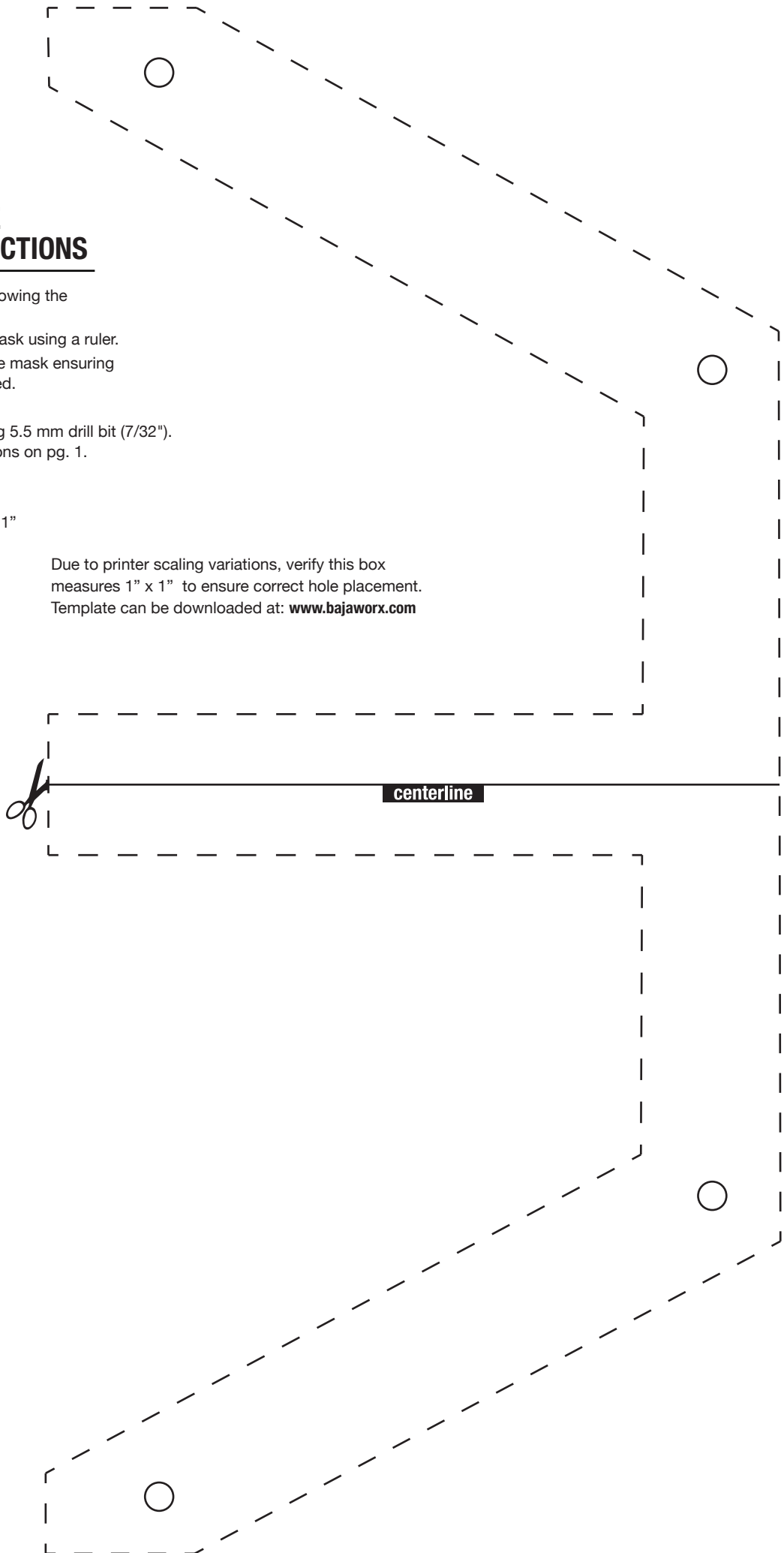

 We will work with you on your custom project.
Send us a photo of your ride!